

MiR

MiR1200 Pallet Jack





MiR

AMT

MiR1200 Pallet Jack – Smarter Moves, Faster Results

Revolutionizing Material Handling with AI-Powered Efficiency

The MiR1200 Pallet Jack is the latest innovation in smarter, faster, and more efficient material handling. This state-of-the-art solution combines intelligence, robust power, and industrial-grade quality to provide streamlined pallet detection, transport, and delivery from floor-to-floor.

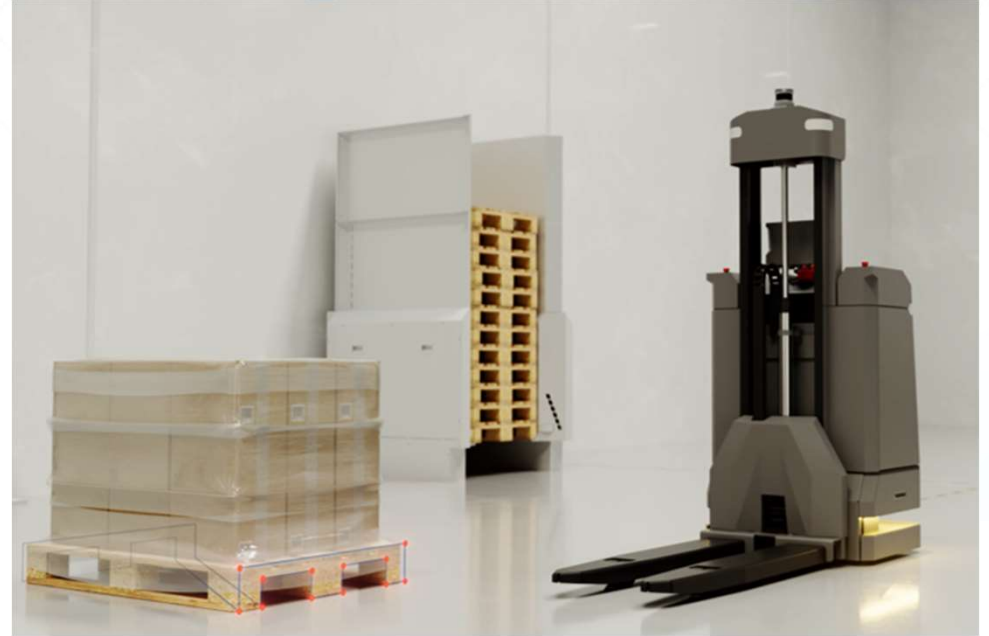

MiR1200 Pallet Jack



Prototype at MiR

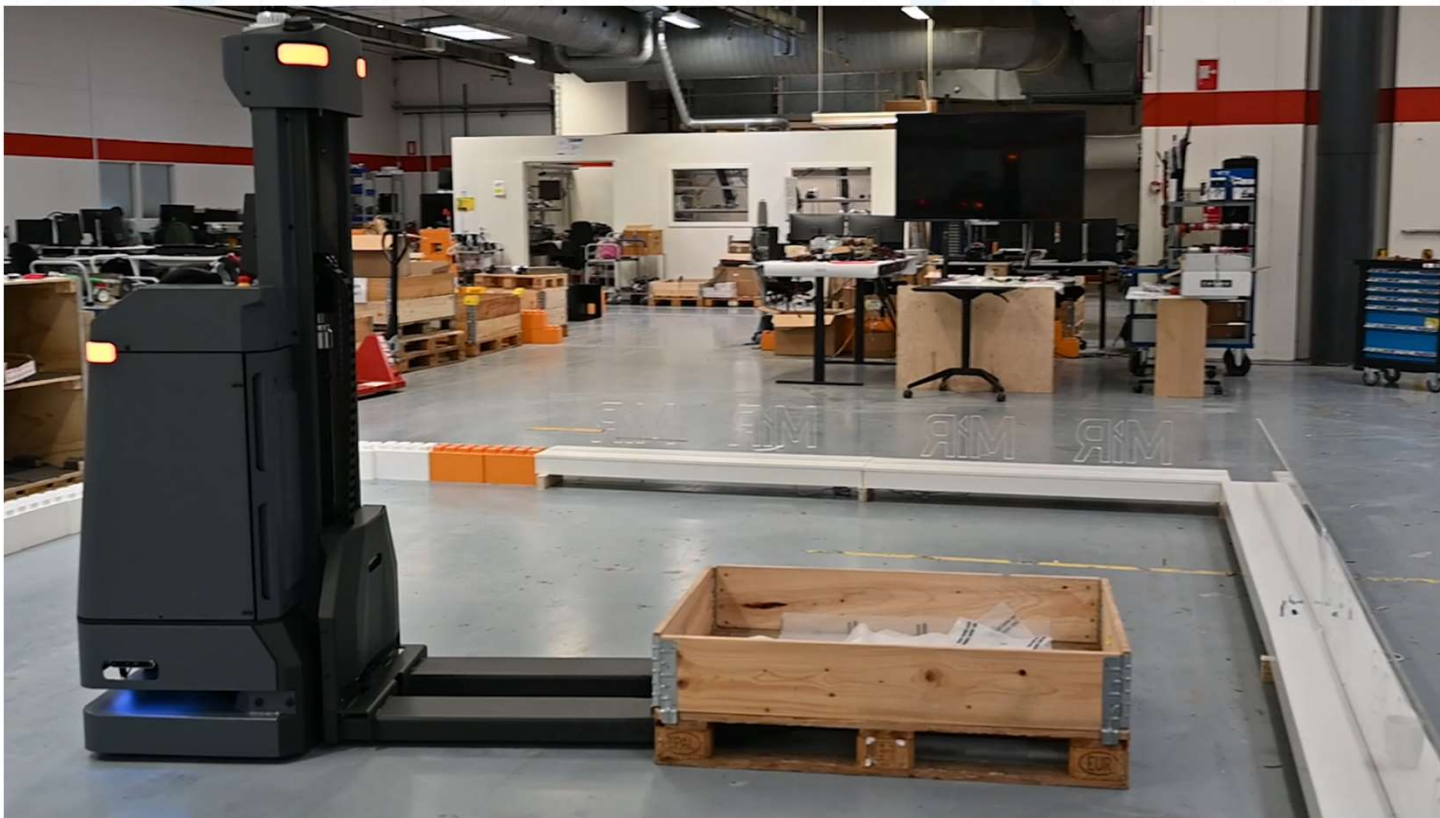

Product Specifications



Specifications

Payload	1200 kg
Max Speed	1.5 m/s
Max Pick/Place Height*	85 cm
Safety	ISO3691-4
Dimensions (mm)	W=820 L=1934 H=1990
Charge Ratio	1:14

*The pick/place at heights is a software feature that is not targeted to be available at launch.

Why MiR1200 Pallet Jack?



Maximized Throughput

Maximize throughput with optimized pick-and-place cycle times enabled by AI-based perception system



Designed for Scalability

Scalable, easy-to-deploy solution with lowest TCO, empowered by the same mature and user-friendly software for all MiR robot types



Efficient, Reliable Operations

Increase efficiency with the reliable robot for operations in challenging environments enabled by MiR's hardware and software combined with LogiTrans' extensive lift product know-how



Enhanced Safety

Ensure employee safety by complying with the latest safety and compliance standards



Improved Performance

Improved performance and uptime by end-to-end service and support to customers on entire AMR journey backed by Teradyne – trusted provider to enterprise customers



A One-Stop Shop for Your Material Handling Needs

- **New application use cases:** the MiR1200 Pallet Jack expands MiR's capabilities by facilitating pallet movement from floor to floor, introducing new application use cases to our existing robot lineup.
- **An enhanced product lineup:** with the addition of the MiR1200 Pallet Jack, MiR now provides AMRs tailored to handle all common internal transportation tasks, including the movement of light-to-heavy payloads and pallets throughout customers' value chains.
- **Streamlined fleet management:** all MiR robots feature the same intuitive interface and can be efficiently managed together through MiR Fleet, ensuring seamless deployment, efficient operations and scalability.



Different robots, different tasks, one fleet management system

Ideal Workflows – Inspiration for Where to Start

At launch, the Pallet Jack is aimed at some key movements of EU pallet in floor-2-floor use cases. This will enable multiple added benefits of MiR robots.

Product Launch Q4 2024



Staging



End-Of-Line Put Away



Capabilities at launch:

- > Same environments as today
- > Floor-2-Floor applications
- > Standard EUR-Pallets with 1200 kg payload



Elevated Pick/ Place 2025



Staging pallets



Benefits:

- > ROI & TCO
- > Cycle time
- > Compliance
- > Useability
- > Flexibility



Target Customers and Workflows

Customers whose operations mainly use wooden European pallets and facilities that do not utilize very narrow aisles. Initial deployment to current customer base will accelerate market adoption.

Long-haul transports are done manually today. Look for long “dead hauls.”



Empty pallet management operations. Either feeding production lines or removing from them.



Steady operational flow with predictable task times.



Finished goods end-of-line operations to staging areas or pallet wrapper areas.



MiR1200 Pallet Jack

Competitive Advantages



Unique Features

- **AI-based perception** enables shrink-wrapped pallet recognition and rapid, precise, and reliable pallet detection
- **Build for challenging environments** with IP52 rating and reliable industrial design, created through collaboration with Logitrans, leveraging +80 years of lift-product expertise
- **Features high battery capacity** and fast charging, ensuring seamless operation in 24/7 workflows.
- **Integrates seamlessly with MiR Fleet** alongside other MiR robots.
- **Incorporates load-jam detection**, which enables the robot to safely interact with compromised pallets.
- **Tiller:** is easy to operate for people used to work with electrical forklifts
- **Analyzes the landing zone** of the pallet prior to placing it
- **Detects and avoids obstacles** up to the full height of the robot
- **Complies to ISO 3691-4 safety standard** and offers comprehensive 360-degree safety coverage.



Competitive Advantage

AI based pallet detection system

Current AMR Pallet Jacks are slow and inefficient

Most AMR Pallet Jacks / Forklifts use 2D Lidar to detect pallets

- Limited ability to recognize a pallet if stretch wrap covers the pallet
- Nearby objects have the risk of being identified as a pallet support block
- Limited ability to recognize a pallet if it isn't correctly placed to tight tolerances

Consequence

- Transportation bottlenecks
- Long cycle times
- Missed picks
- Toppling of pallets

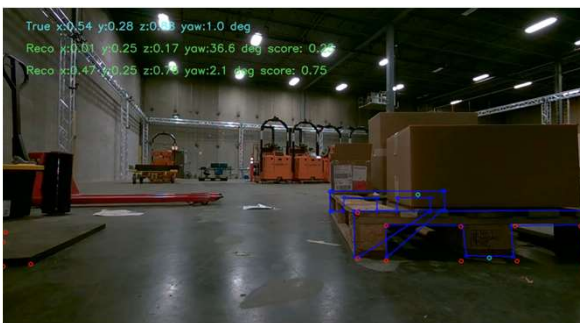
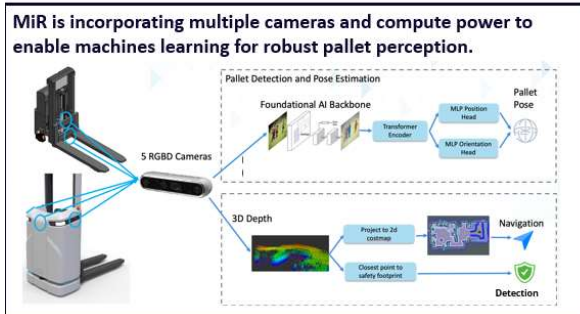
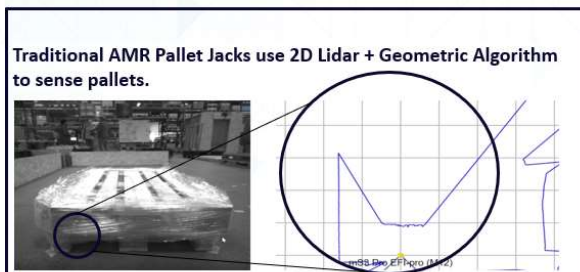

MiR1200 Pallet Jack - solution

MiR1200 Pallet Jack features AI-based pallet detection system

- AI-powered perception system enabling recognition of stretch wrap pallets
- The MiR1200 Pallet Jack detects pallets while on the move for fast pick-up and continually updates its path planner
- Will only recognize the pallet itself and not other objects nearby

Customer Benefits

- Rapid, precise, and reliable pallet detection for consistent throughput and low operating costs
- Pick and place times significantly reduced, leading to faster ROI
- Greatly reduced failed picks that require manual intervention

Competitive Advantage

Rugged industrial design built for real world applications

AMR Pallet Jacks lack industrial durability in challenging environments

- AMR Pallet Jacks are often used in challenging environments but may not be constructed with industrial-grade components
- Omnidirectional wheel maintenance challenges: while small omni wheels enhance agility, they often require frequent replacement and cannot be used in "brownfield" sites

Consequence

- Unforeseen repair costs
- Susceptibility to wear and tear in rugged conditions, reducing overall product lifespan
- Downtime and operational disruptions occur due to the need for ongoing wheel maintenance, impacting overall efficiency.



MiR1200 Pallet Jack - solution

- Reliable industrial design, created through collaboration with Logitrans, leveraging 80+ years of lift-product expertise
- Rugged, industrial standard drive and caster wheels from 80+ year manual pallet company
- IP52 rating for navigating in challenging environments

Customer Benefits

- MiR1200 Pallet Jack can be used in highly challenging, industrial environments by offering a solution for varied conditions, surfaces, obstacles, and lifting requirements.
- Minimal downtime, less maintenance and lower TCO
- Minimal to no "prepping" of the floor for the MiR1200 Pallet Jack.



Floor discontinuities become irrelevant

Competitive Advantage

Accessible, easy-to-use tiller for manual mode

Customers don't have (enough) people allocated to work with automation

- Usually, customers only have a couple of people dedicated to work with their automation equipment
- After deployment, interacting with automation equipment in case of smaller issues can be difficult for people used to working with manual equipment

Consequence

- Downtime of AMR pallet jacks even when only a smaller issue occurs if dedicated technical people are off work
- People do not accept the product as they cannot collaborate with it
- Operators lose belief that robots can help them with their day-to-day jobs



MiR1200 Pallet Jack - Solution

- The MiR1200 Pallet Jack has a Tiller for semi-automated handling
 - Used for simple mapping of the area
 - Enables employees that are used to operating electrical pallet stackers to interact with the MiR1200 Pallet Jack
 - Simple troubleshooting becomes accessible to a wider variety of skillsets

Customer Benefits

- Instead of only 2 or 3 people (automation=engineers) in the facility who know how to=troubleshoot, having a manual tiller opens the=pool of possible personnel who can interface with=the robot to anyone in the facility
- Increased sense of ownership among employees
- Improves employee confidence and morale

Competitive Advantage

3-dimensionable object detection to the full height of the robot

Current AMR Pallet Jacks have challenges interacting with dynamic environments

- Many customer sites are brownfield sites with narrow aisles, equipment on the floor, and highly dynamic surroundings. These are difficult for current AMR pallet jacks to operate efficiently in.
- Travel paths often become littered with small trash and objects hanging down from above or sticking from the side (such as forks from other forklifts).

Consequence

- Inefficient AMR pallet jack workflows leading to transportation bottlenecks
- Risk of damaging the robot and customer goods with obstacles that standard detection systems can not see

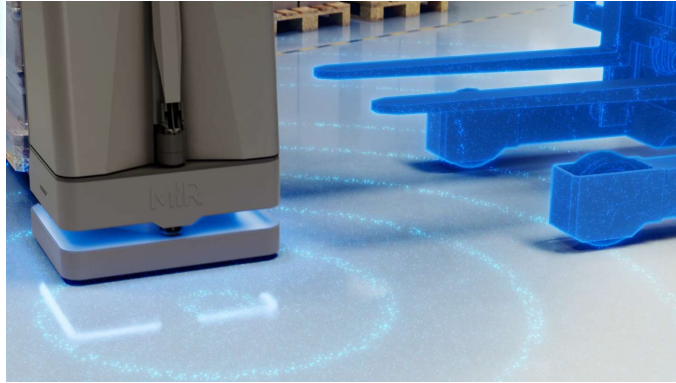

MiR1200 Pallet Jack - Solution

- Detects and avoids obstacles up to the full height of the robot, such as objects on the floor typical for industrial environments.
- Recognizes forks from other forklifts and avoids them.

Customer Benefits

- Reduced equipment & product damage
- Time savings through efficient navigation in complex environments
- Quality enhancement by accurate object detection

Challenges



Redirecting Internal Resources for Higher-Value Tasks



Challenge

Labor shortage and rising labor costs require enterprises to automate to redirect people for higher value tasks

Need

Companies need efficient robots that can work full shifts and have high ROI

Feature

- AI-based pallet detection system for fast pallet picking time and shrink-wrapped pallet recognition/picking
- Charging ration 1:14 and opportunity charging
- For an average workflow, robot can last for 10 hours on a single charge
- 1.200 kg payload

Benefit

- AI-based pallet detection leads to operational efficiency, accuracy, and overall performance. Reduced pick-and-place cycle times lead means increased productivity and throughput gains and therefore better ROI
- The robot has sufficient battery capacity to run for 1 full shift (depends on the specific use case)
- A 24h cycle requires less than 2h total charging time. This results in a higher output per robot.
- The high payload capability means you can move the same amount with fewer mission cycles/deliveries, improving productivity and throughput. This also translates to a shorter ROI since the robot can move more at a time.

Uptime, Uptime, Uptime



Challenge

Cost pressures and competitive landscapes across industries

Need

Customers need reliable robots that run without errors and downtime. A robot standing still or not able to deliver pallets not only unacceptable, it is expensive.

Feature

- Reliable industrial design, created through collaboration with Logitrans, leveraging their +80 years of lift-product expertise
- Leverages MiR's many years of software expertise for efficient navigation
- 3D landing zone analysis
- Vertical obstacle avoidance
- Manual tiller for semi-automated operation

Benefit

- Utilizes industrial grade drive and caster wheels leading to lower repair costs, less required maintenance and thus minimizing downtime
- Leveraging Logitrans' specialized knowledge on lift-product provides durability, optimized performance, and efficient material handling capabilities, offering solutions for varied conditions, surfaces, obstacles, and lifting requirements.
- The MiR1200 Pallet Jack navigates efficiently in challenging and dynamic environments thanks to MiR's software capabilities designed to maximize productivity
- The MiR1200 Pallet Jack analyzes its surroundings, both around it (including forks from other vehicles) and overhead, leading to time savings through efficient navigation, agility improvement with adaptable navigation and quality enhancement by accurate object detection.
- For employees used to working with electrical stackers, the manual tiller empowers them to operate the MiR1200 Pallet Jack, ensuring less downtime if smaller issues arise

Creating a Safe Work Environment



Challenge

Workplace safety and employee satisfaction

Need

Customers need a safe alternative to traditional injury-prone forklifts or trucks

Feature

- Designed to comply with ISO 3691-4
- Full 360-degree safety coverage
- Load jam detection
- Extensive documentation package from MiR

Benefit

- Assurance of a safe working environment
- Reduced risk of accidents and costly legal compliance
- Better reputation and increased employee satisfaction
- Assurance that comes from MiR's 10-year track record of AMR safety excellence

Technical Details



Agility

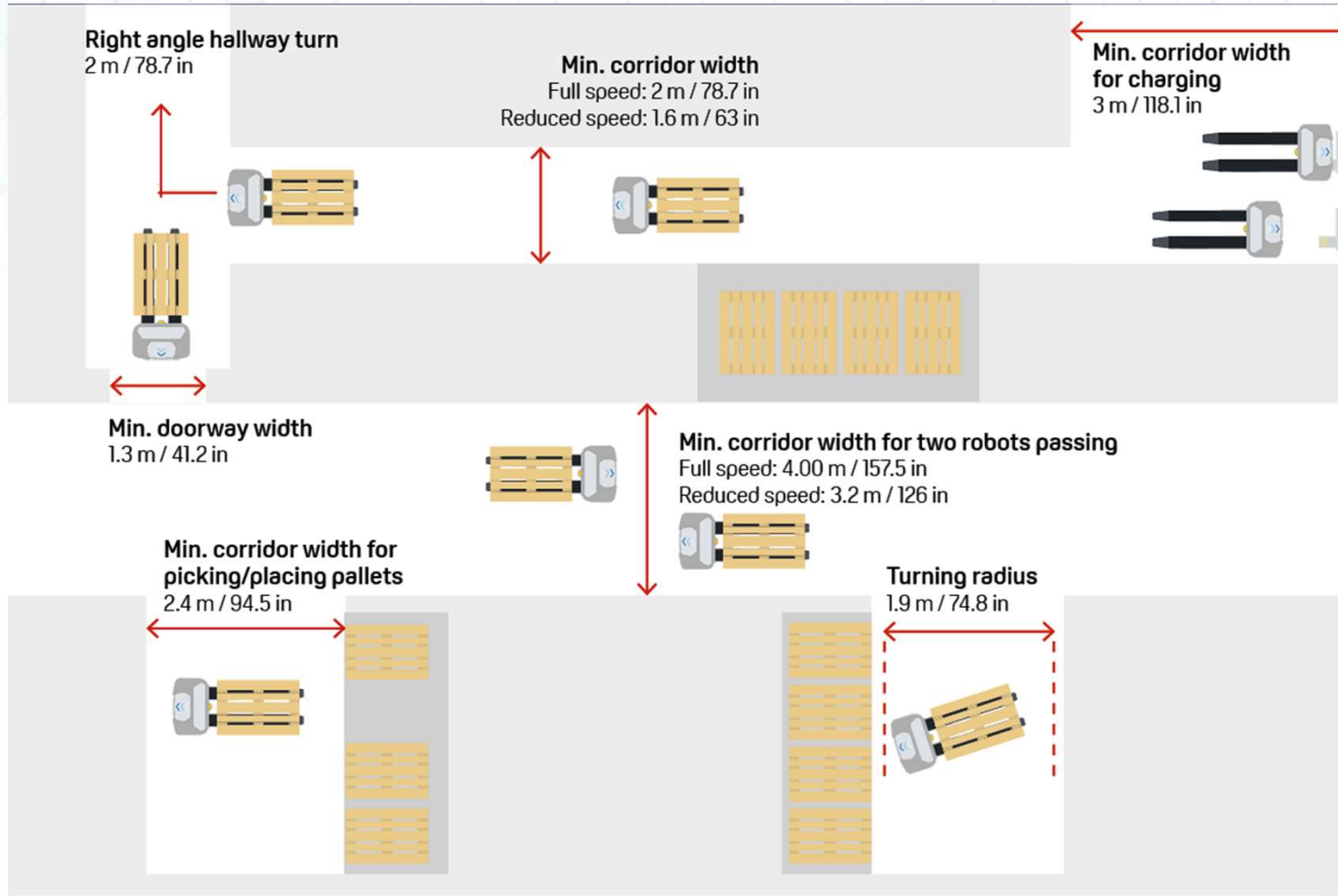

Specifications are subject to change and expected to be improved
Specifications may vary based on local conditions and application setup and are subject to change
Pallets must be spaced 10 cm from one another (including overhang)
Pallets must be spaced 20 cm from rigid infrastructure, such as walls

Layout

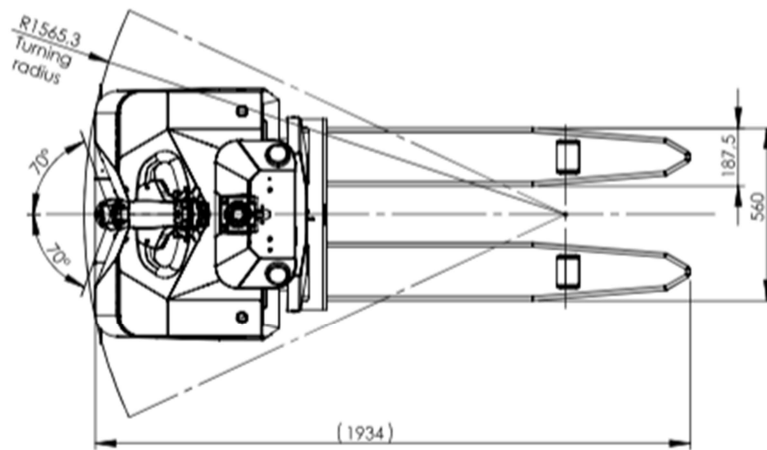
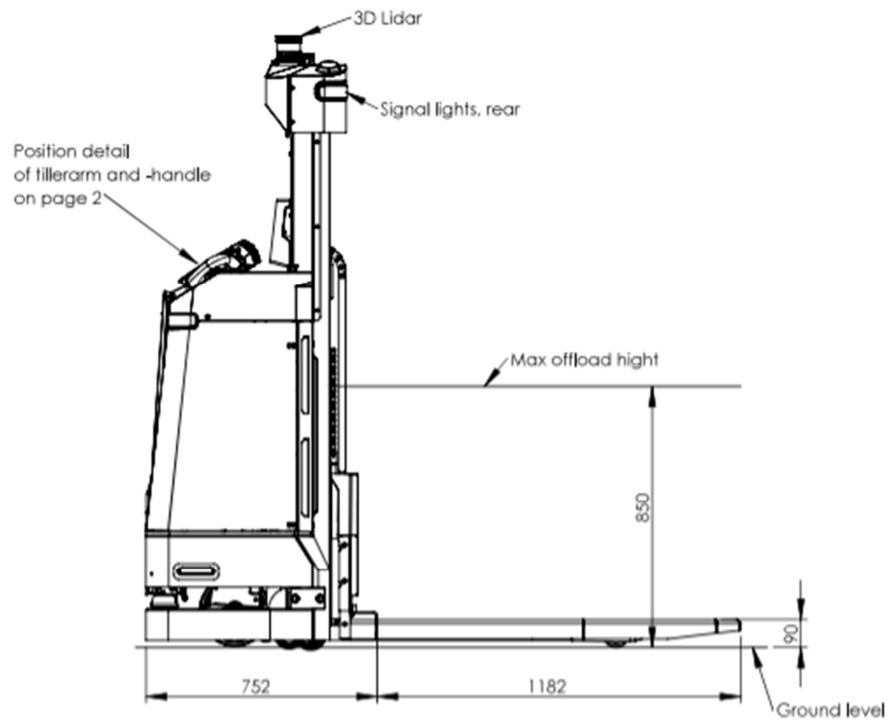
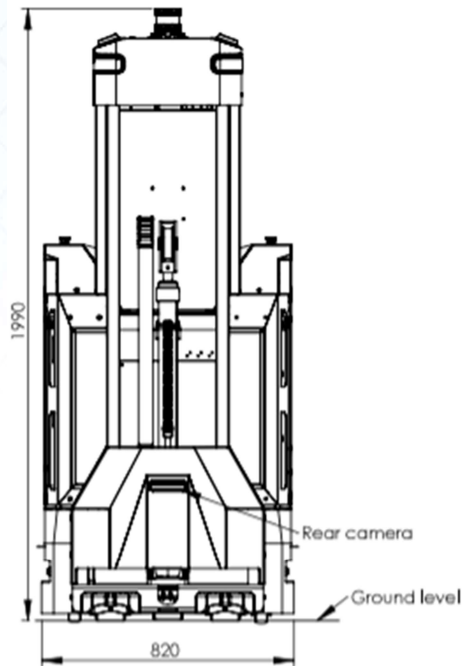

Safety and Obstacle Detection

Ensure your employees' safety by complying with relevant safety standards including ISO3691-4. The pallet jack comes with:

- Fusion sensor input from RGBD cameras, 2D and 3D LIDARs ensuring robust detection
- Full 360-degree coverage to ensure coverage from all angles
- 3D sensing to ensure detection beyond the floor including overhangs and forks.
- An extensible software platform that supports future AI enhancements

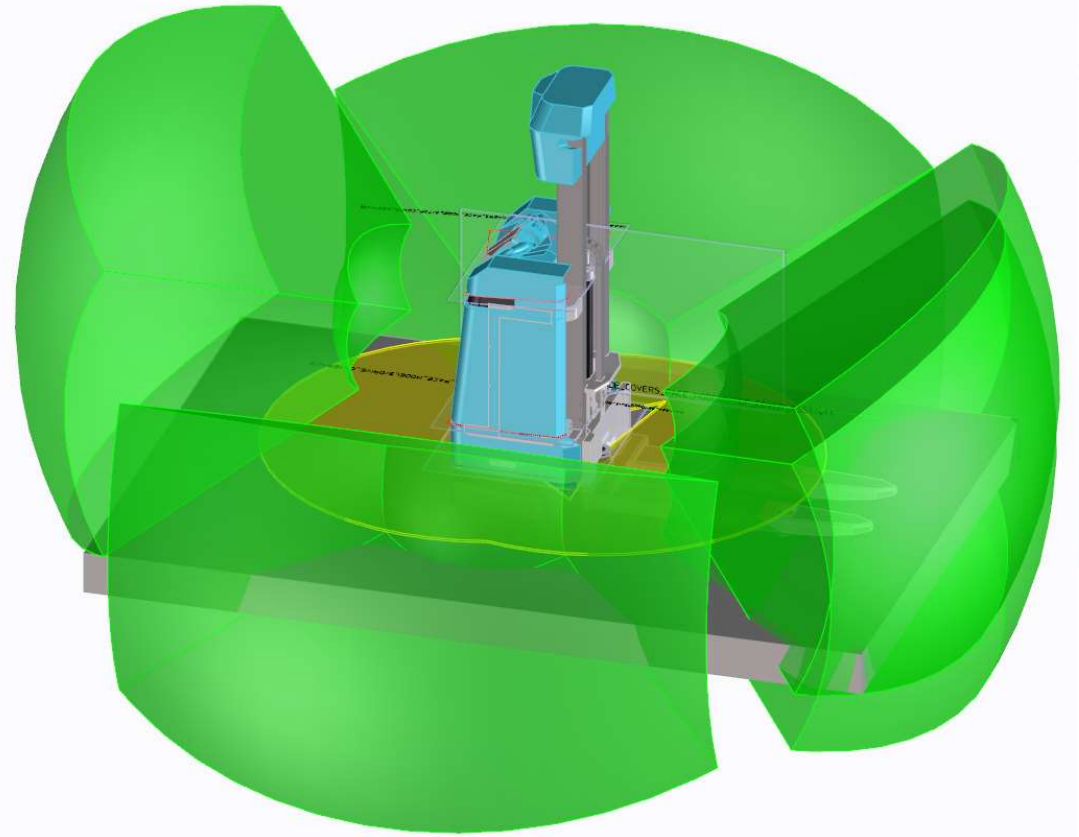

Load Jam

- Broken pallets create picking hazards
- MiR1200 Pallet Jack recognizes when the pallet is moving or not moving relative to itself as intended
- MiR1200 Pallet Jack reacts appropriately to ensure the safety of people, the machine, and the product

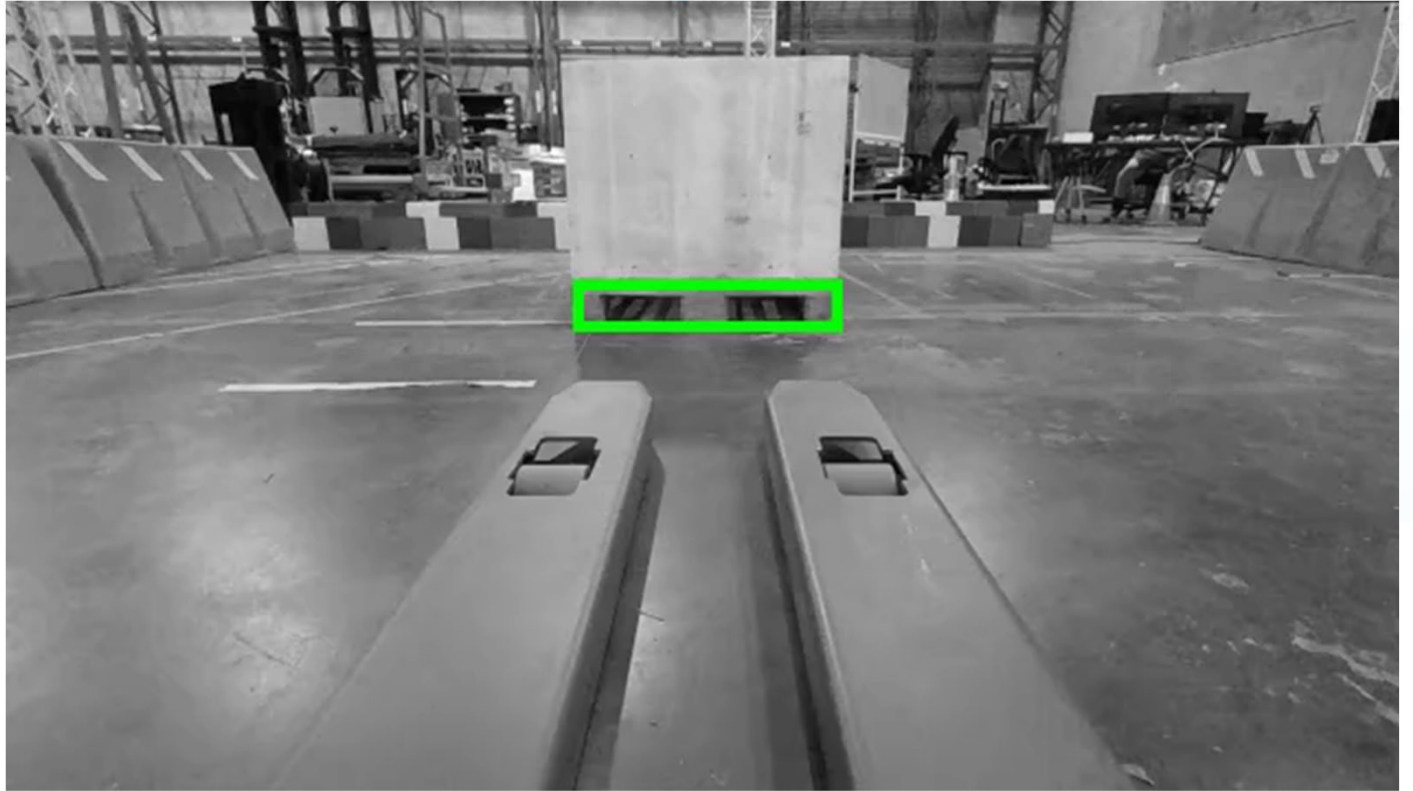

*Prototype, not a production vehicle

Pallet Perception

Pallet Pose & Identification

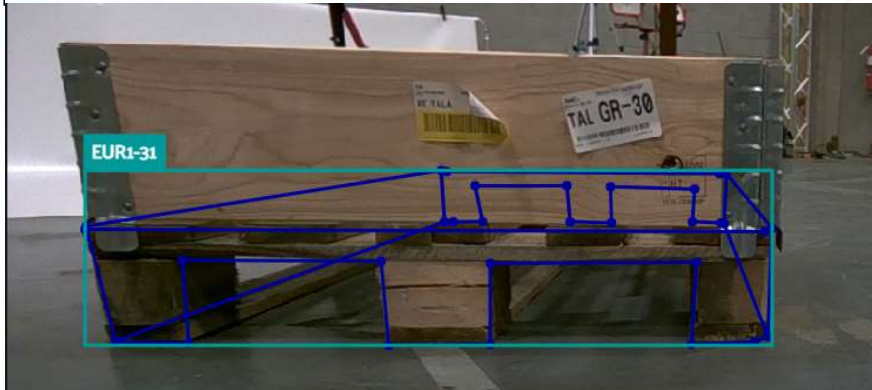

Wrapped Pallet Pick-Up



Note: engineering prototype unit